

LED DRIVING LIGHT INSTALLATION INSTRUCTIONS

Preliminary Steps

1. Read all instructions carefully and study diagrams before installing lights.
2. Check with state and local authorities for laws governing usage and proper mounting of auxiliary lamps.
3. Disconnect ground connection from battery (marked "-") to avoid accidental short circuits before attempting to connect electrical wires.
4. Route new wires along existing wiring. Tape as necessary to correct slack.
5. When running wires through the firewall, keep them away from moving parts.

Mounting Lights

1. Drill 8.5mm holes for screw placement on the surface where you would like to fix the light.
2. Use the bolt to fasten the lamp, add the locking washer and tighten the bolt.
3. Illustration of Multi Mounting Options :Side Bracket & Bottom Bracket.
4. Wiring: Green "+" (Power Regulation), Red "+", Black "-", White "+" (White park light), Yellow "+" (Yellow park light)
5. Function: Red+Black=Full Power, Red+Green+Black=Half of Power(R112 certificate)

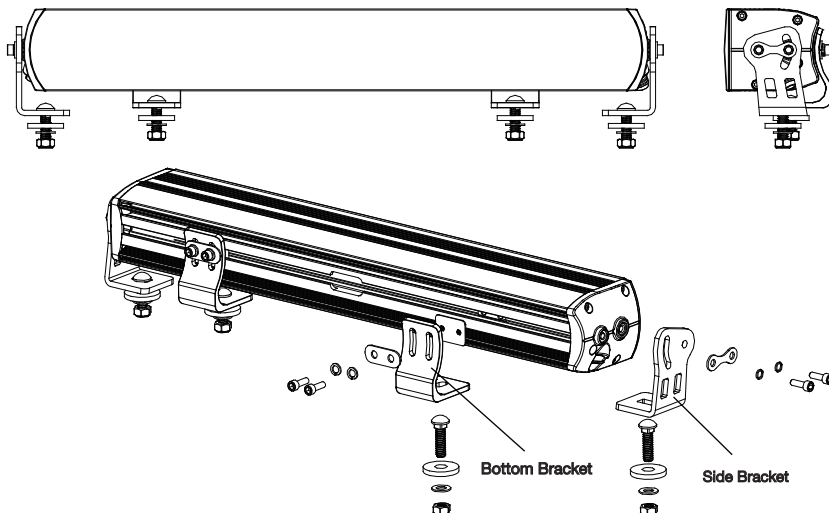

Warning:

1. Work under the specified voltage (DC9-36V).
2. This light becomes hot under continuous use. Don't remove or touch the casing for at least 30 minutes after turning the lamp off.
3. Keep heat-sink clean and exposed to maintain air flow.